

Installation Guide for AC-6000 V1.0

Fingerprint Identification Terminal



Doc. Ver. : V1.00

Apr., 08.2009

R&D Center

Union Community Co., Ltd.

1. Power Connector connection

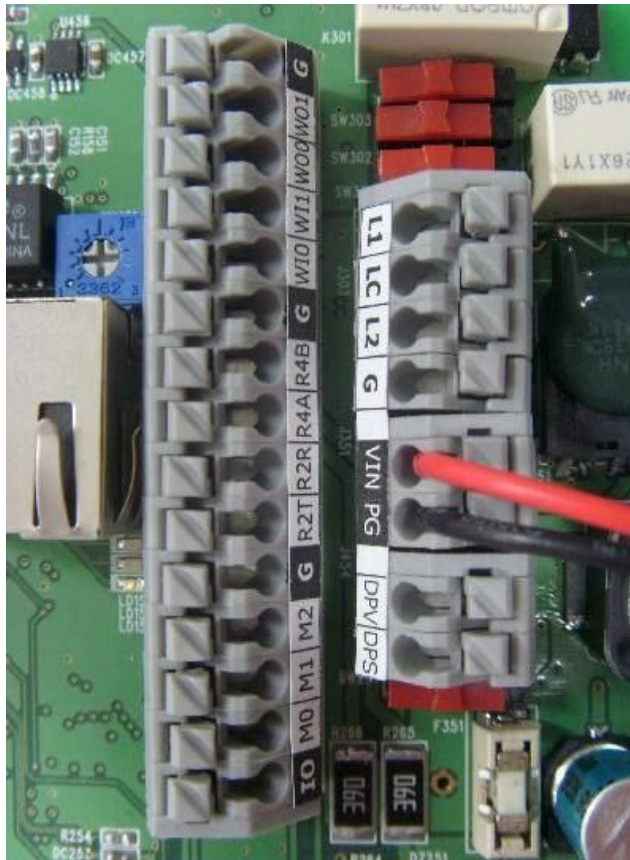
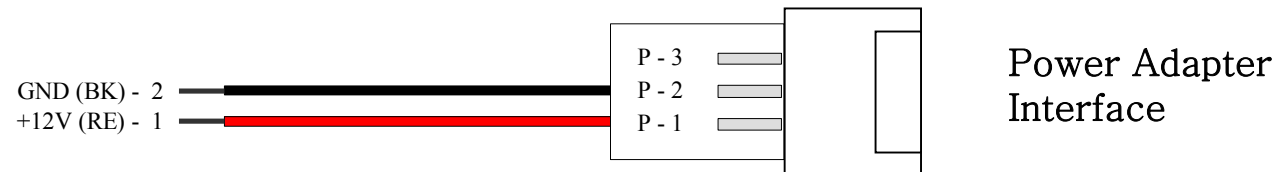

**** Insert the Power Cable to VIN/PG Terminal Block in right color matching as the picture**

2. Connecting Ethernet & Power Cable

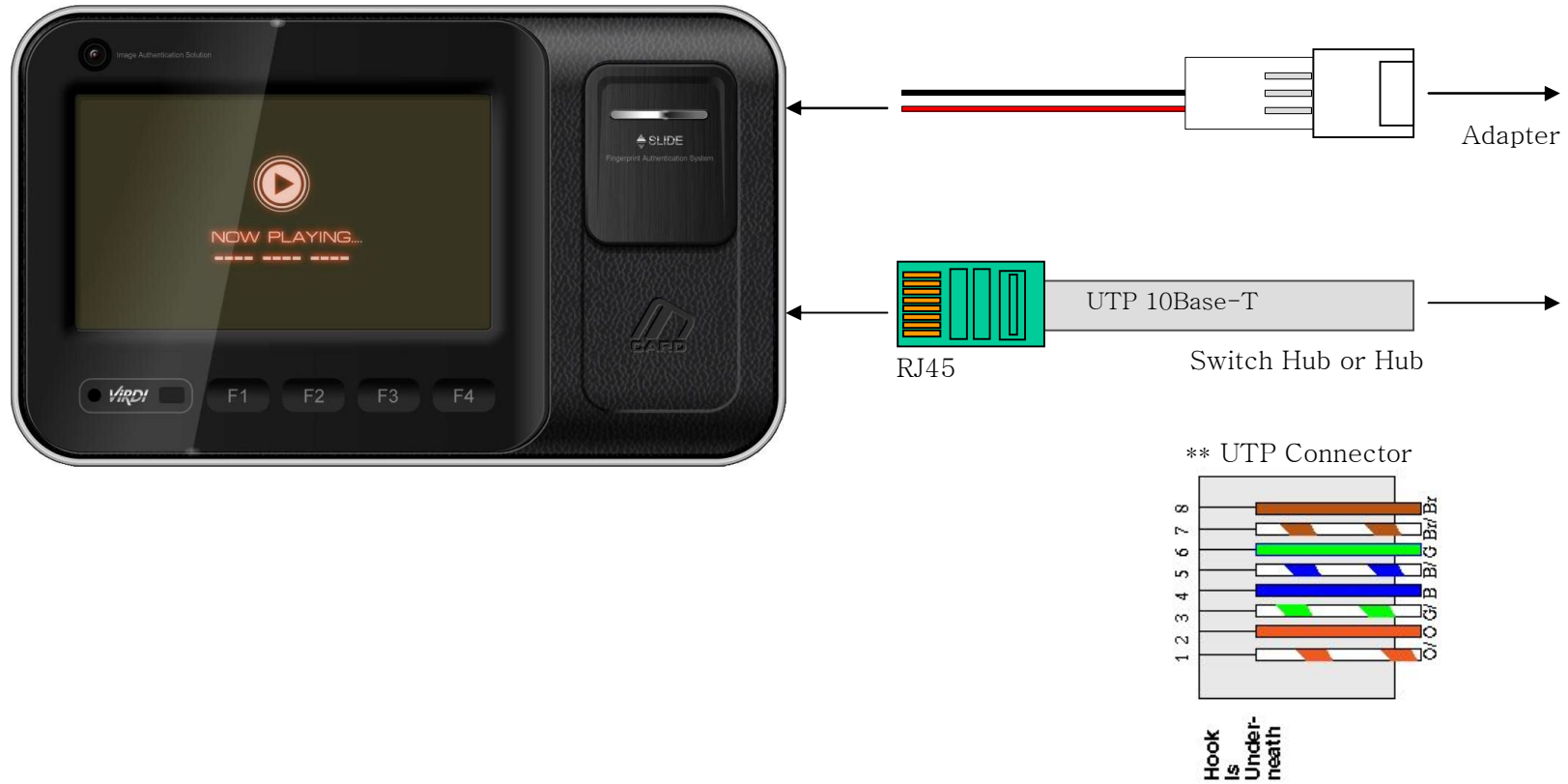

3. Main Board Feature

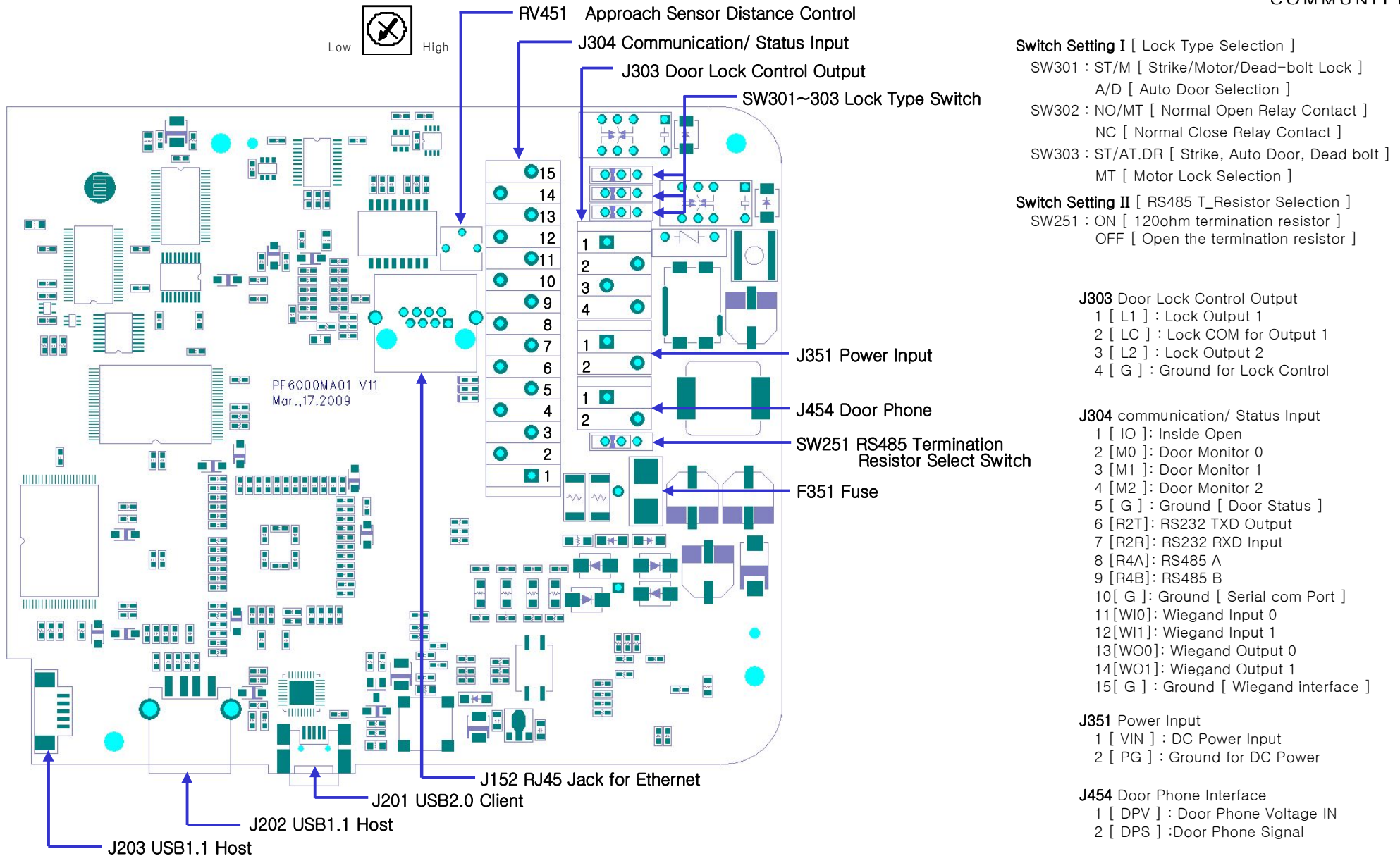

4. Keypad Board Feature

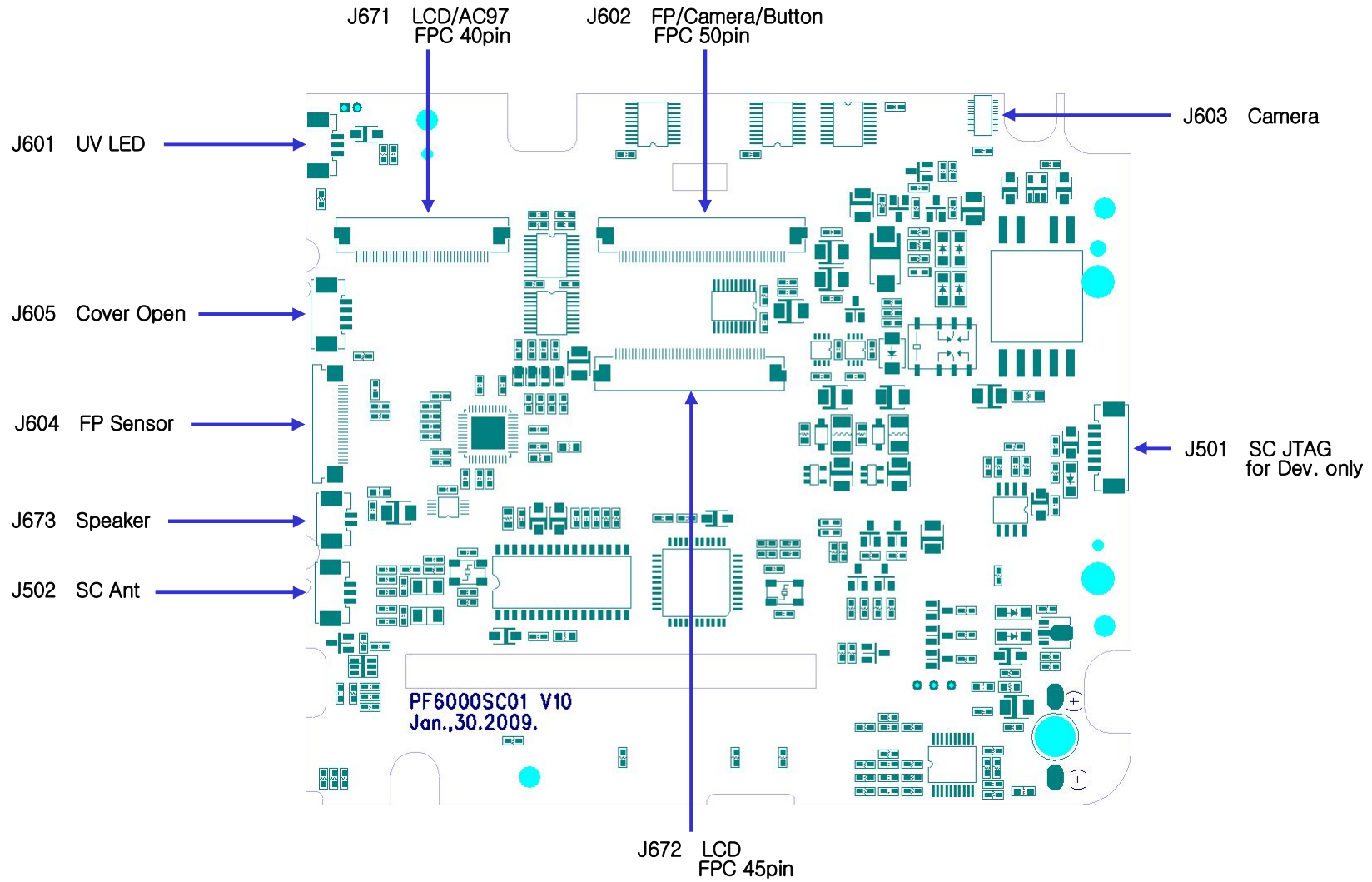

5. Schematic for Door Lock Interface

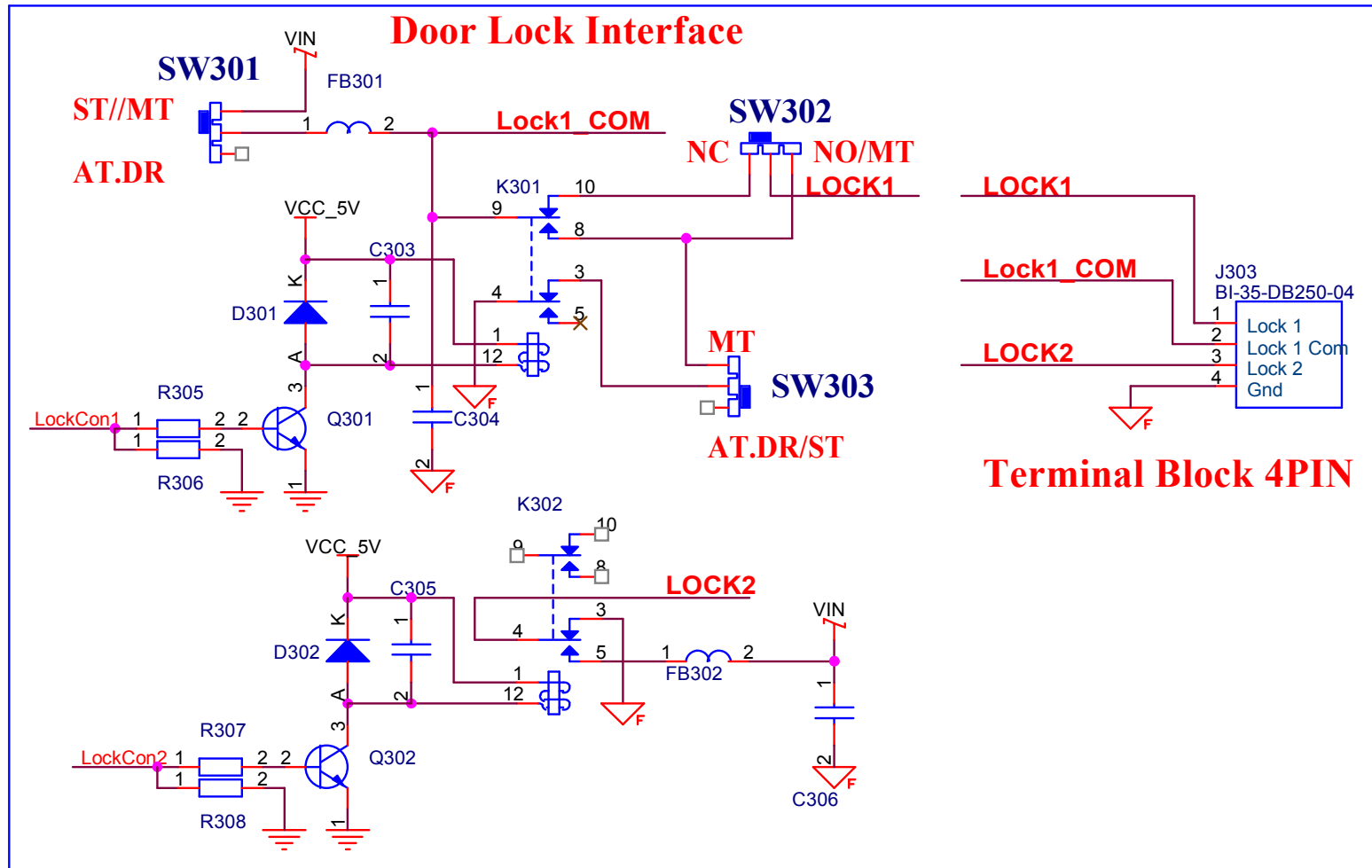

6. Connection of Wires to terminal blocks

J304 communication/ Status Input

- 15 [G] : Ground [Wiegand]
- 14 [WO1] : Wiegand Output 1
- 13 [WO0] : Wiegand Output 0
- 12 [WI1] : Wiegand Input 1
- 11 [WI0] : Wiegand Input 0
- 10 [G] : Ground [Serial Port]
- 9 [R4B] : RS485 B
- 8 [R4A] : RS485 A
- 7 [R2R] : RS232 RXD Input
- 6 [R2T] : RS232 TXD Output
- 5 [G] : Ground [Input]
- 4 [M2] : Door Monitor 2
- 3 [M1] : Door Monitor 1
- 2 [M0] : Door Monitor 0
- 1 [IO] : Inside Open

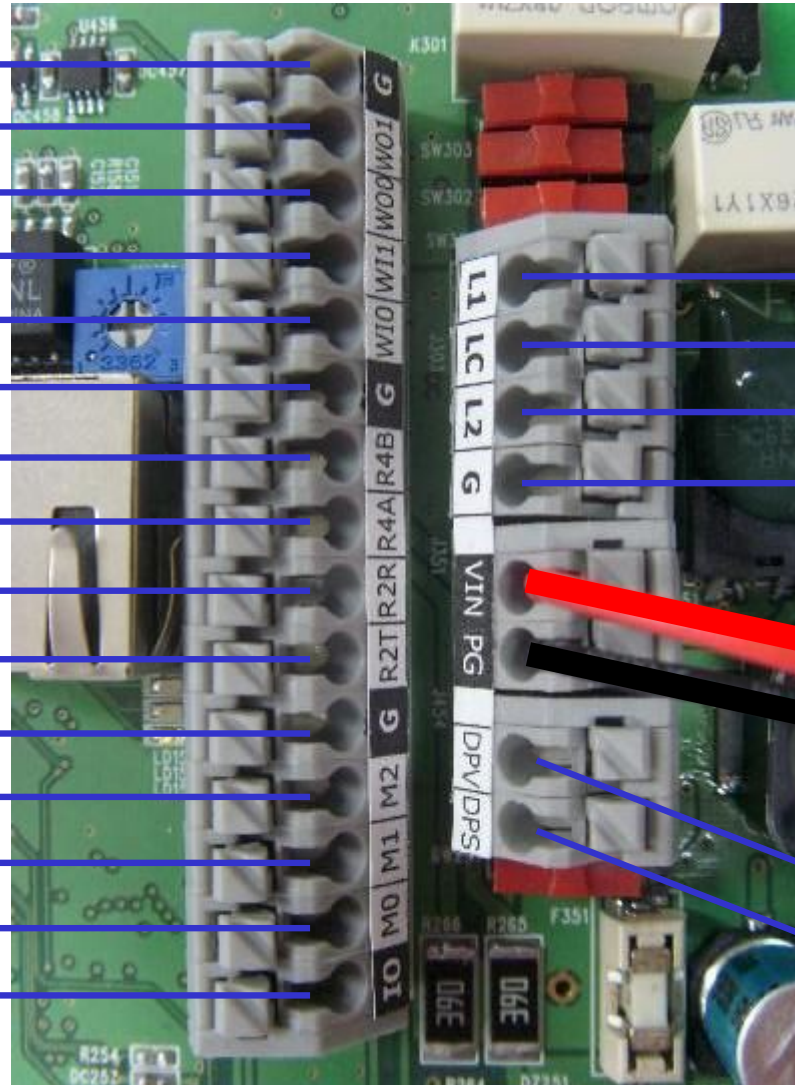

J303 Door Lock Control Output

- 1 [L1] : Lock Output 1
- 2 [LC] : Lock COM for Output 1
- 3 [L2] : Lock Output 2
- 4 [G] : Ground for Lock Control

J351 Power Input

- 1 [VIN] : DC Power Input
- 2 [PG] : Ground for DC Power

J454 Door Phone Interface

- 1 [DPV] : Door Phone Voltage IN
- 2 [DPS] : Door Phone Signal

7. Connection of Door Phone

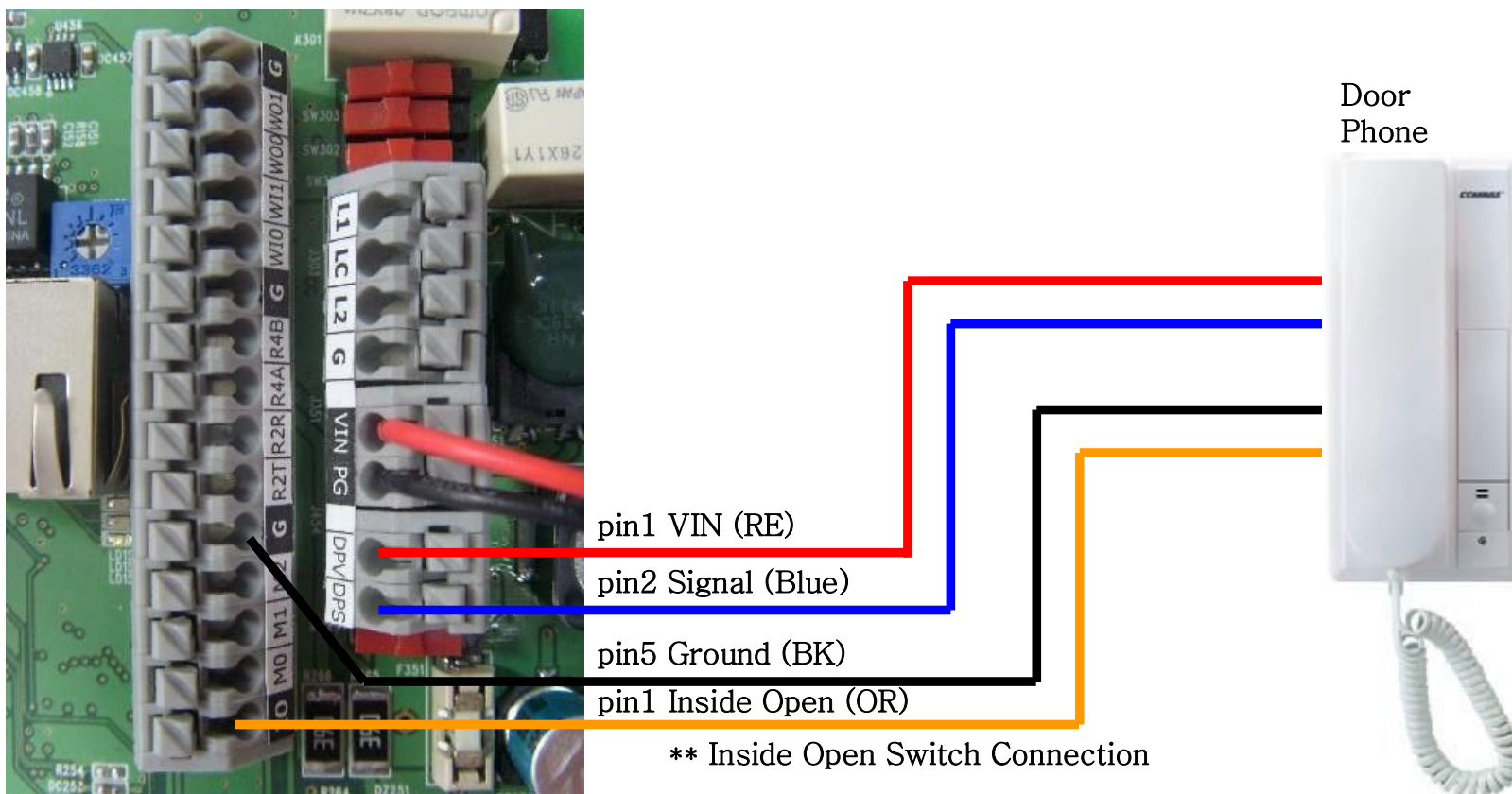

- ※ The Installation distance is Max 30M(100feet) between AC-6000 and Door Phone.
If you want to call the door phone, please use the “Call” button.
- ※ The Color is not important....

8. Connecting Dead-Bolt Type Door Lock (Fail Safe)

8.1. Connect with One System/ One Lock

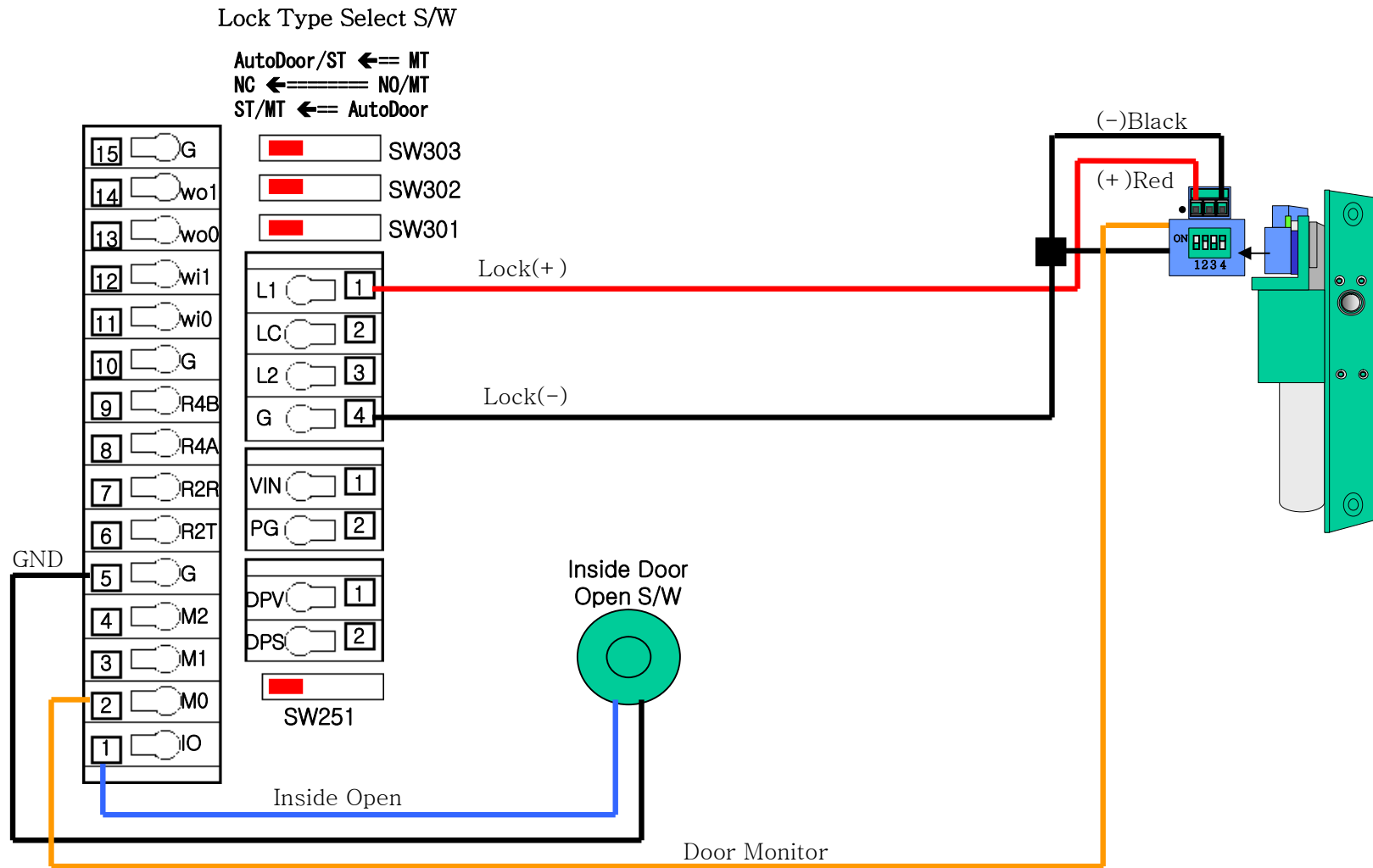

8. Connecting Dead-Bolt Type Door Lock (Fail Safe)

8.2. Connect with Two Systems/ One Lock

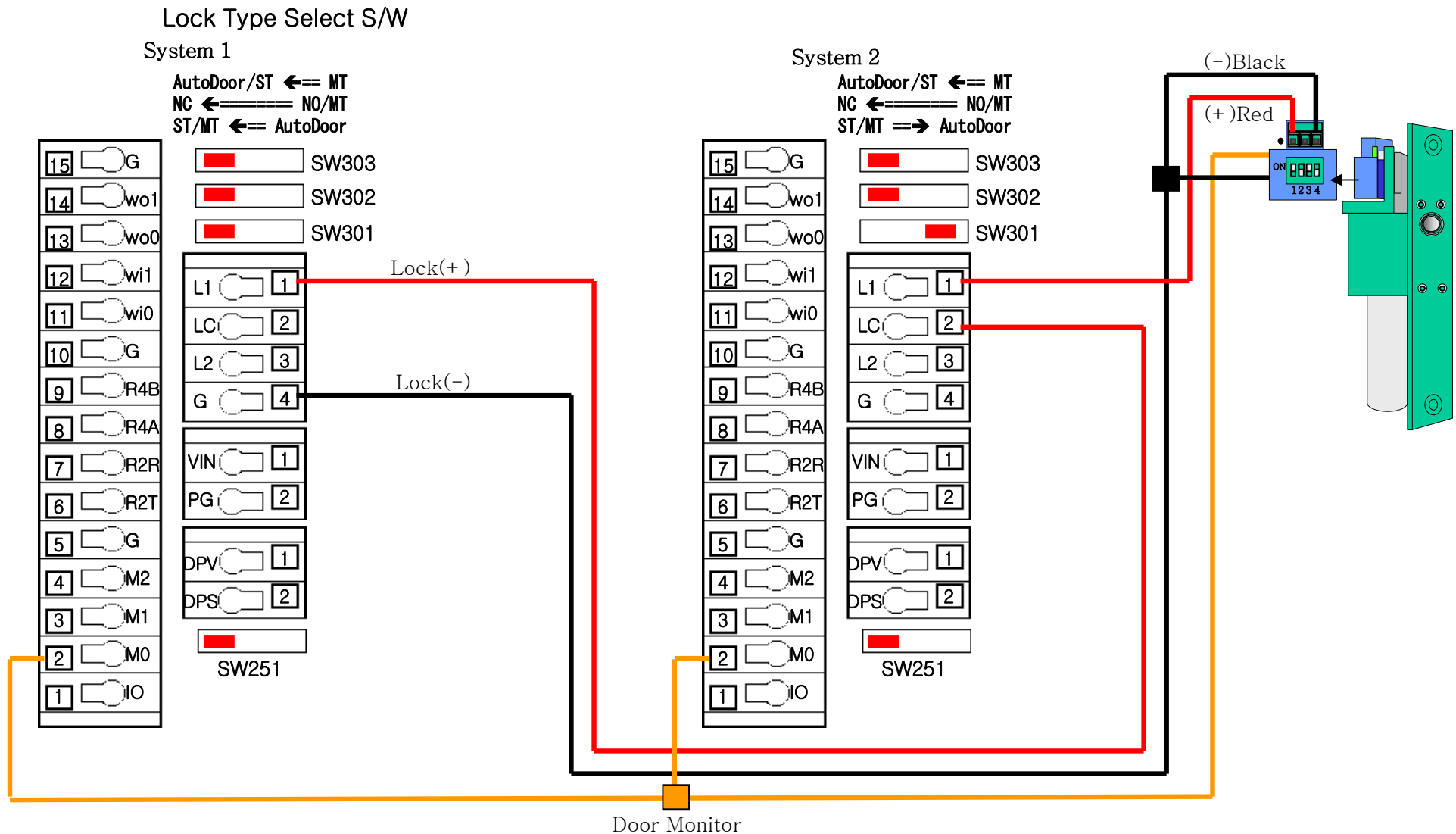

9. Connecting Strike Type Door Lock (Fail Safe)

9.1. Connect with One system/ One Lock

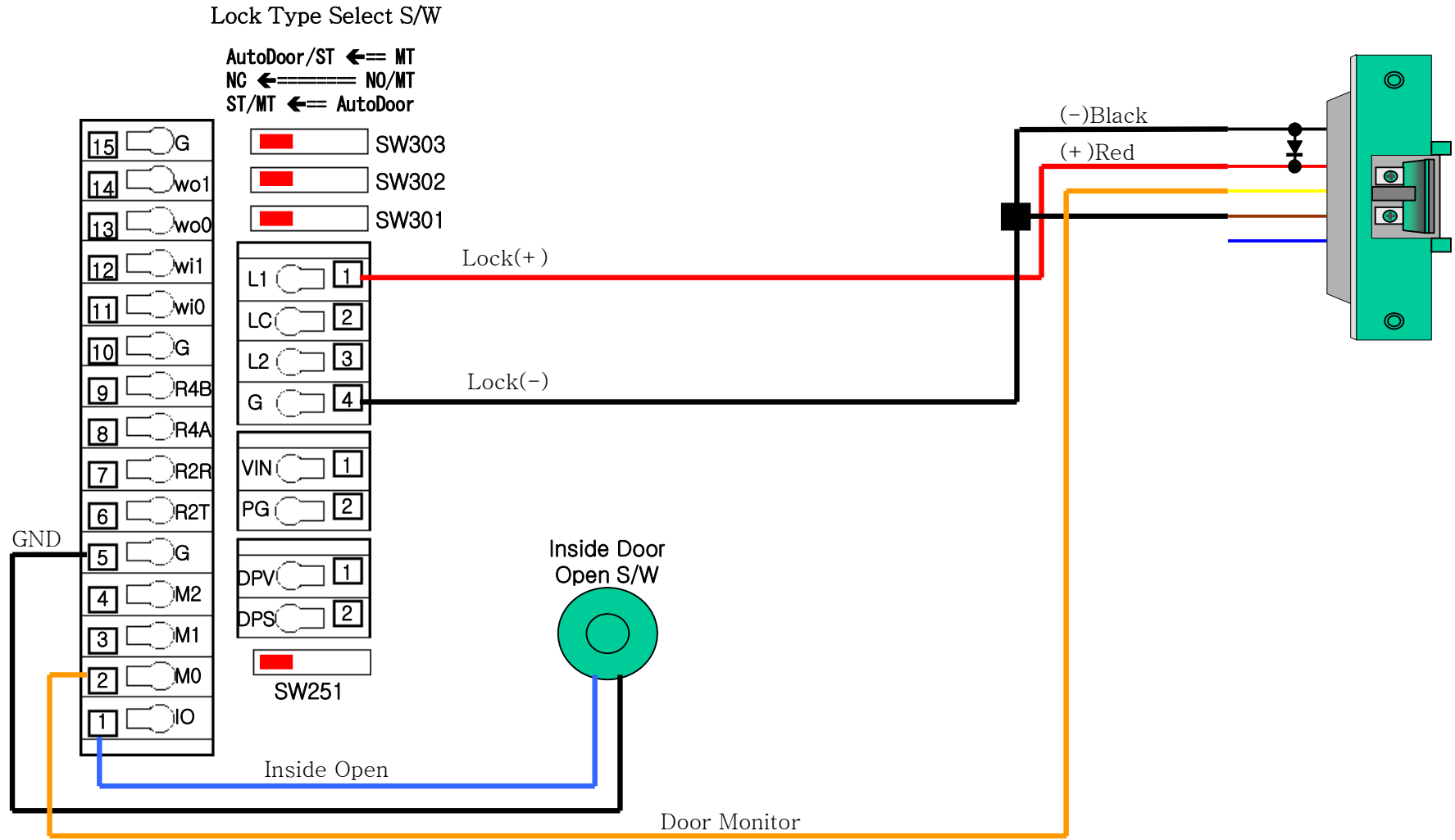

9. Connecting Strike Type Door Lock (Fail Safe)

9.2. Connect with Two systems/ One Lock

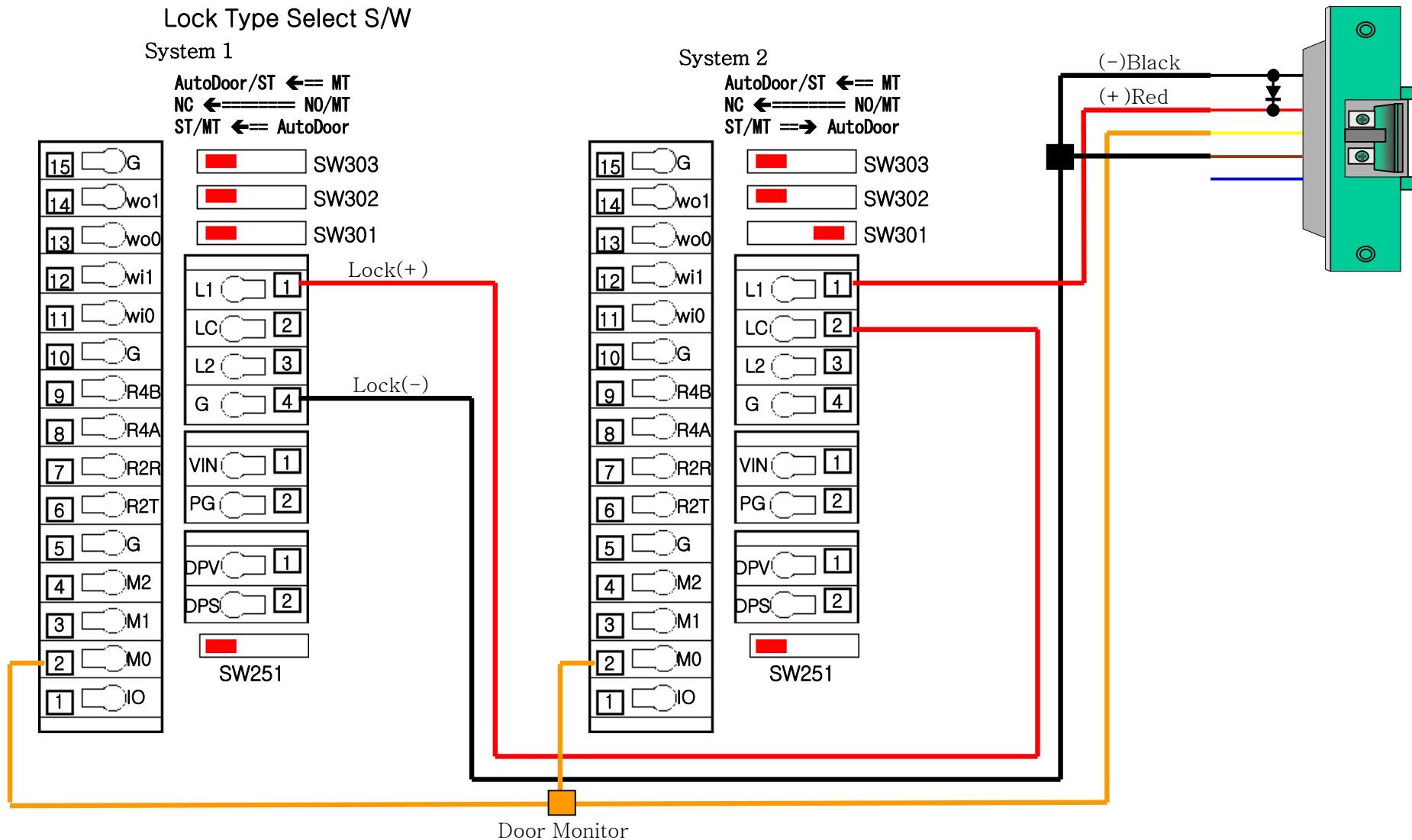

10. Connecting Strike Type Door Lock (Fail Secure)

10.1. Connect with One system/ One Lock

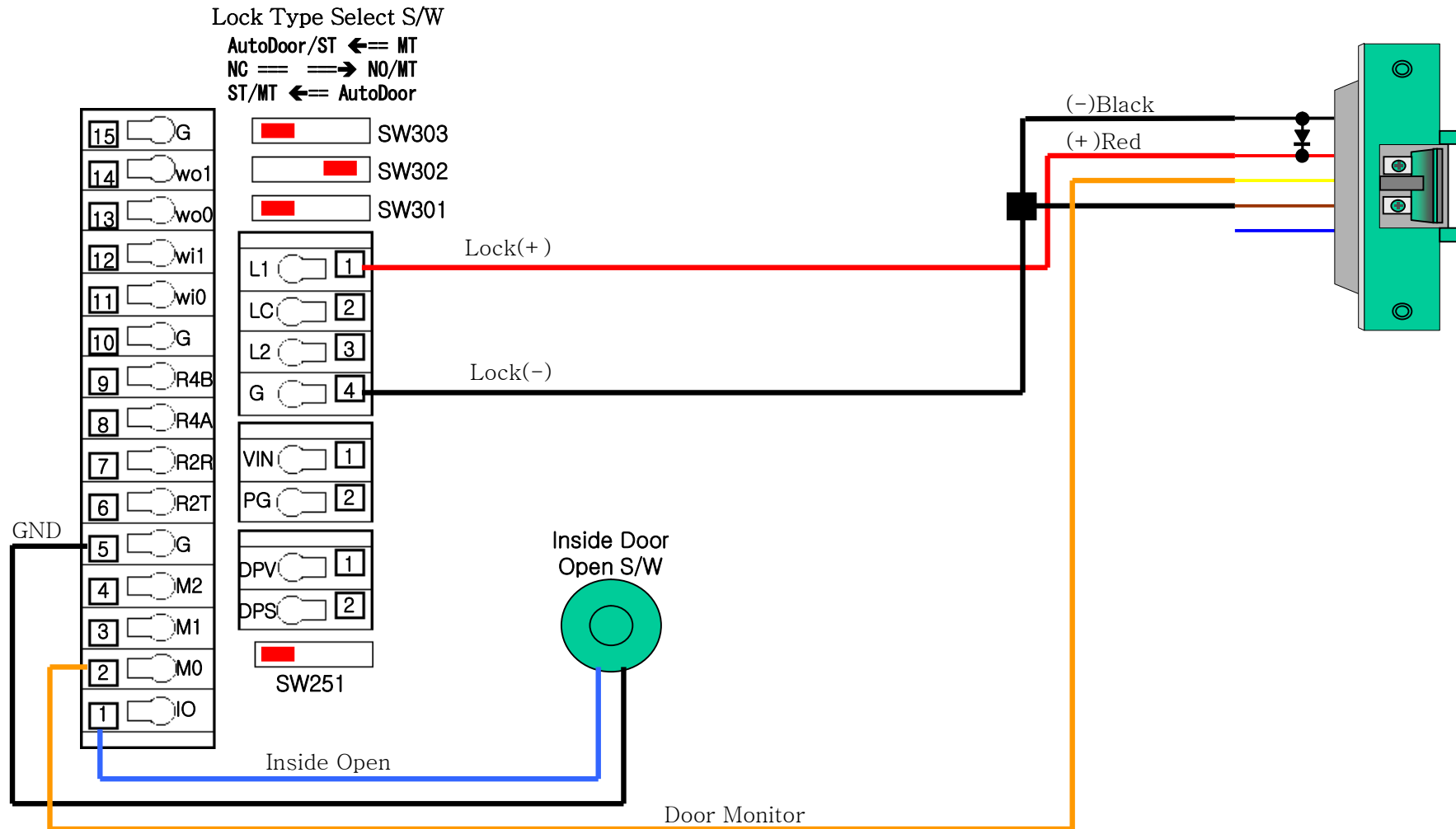

10. Connecting Strike Type Door Lock (Fail Secure)

10.2. Connect with Two systems/ One Lock

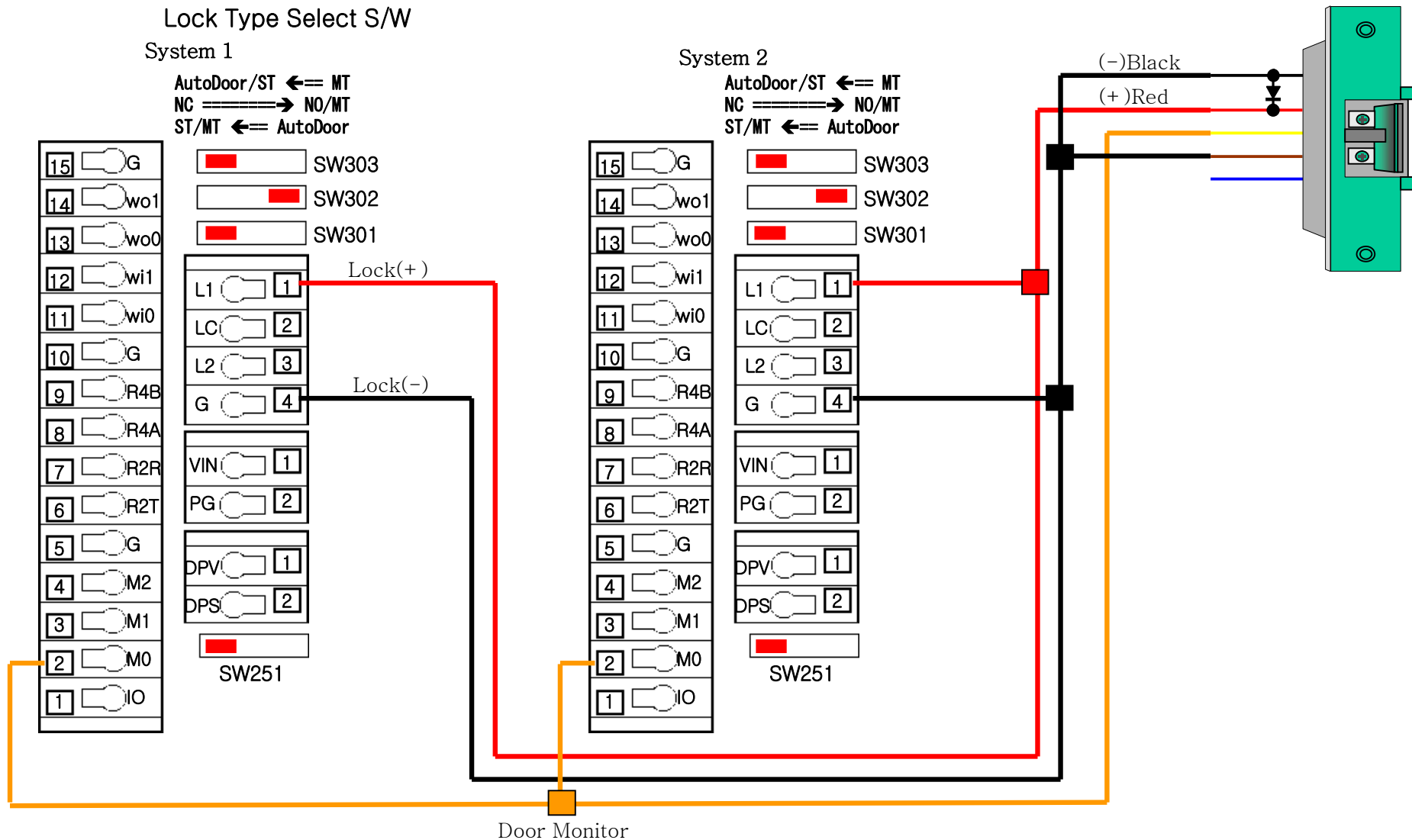

11. Connecting EM Type Door Lock (Fail Safe)

11.1. Connect with One system/ One Lock

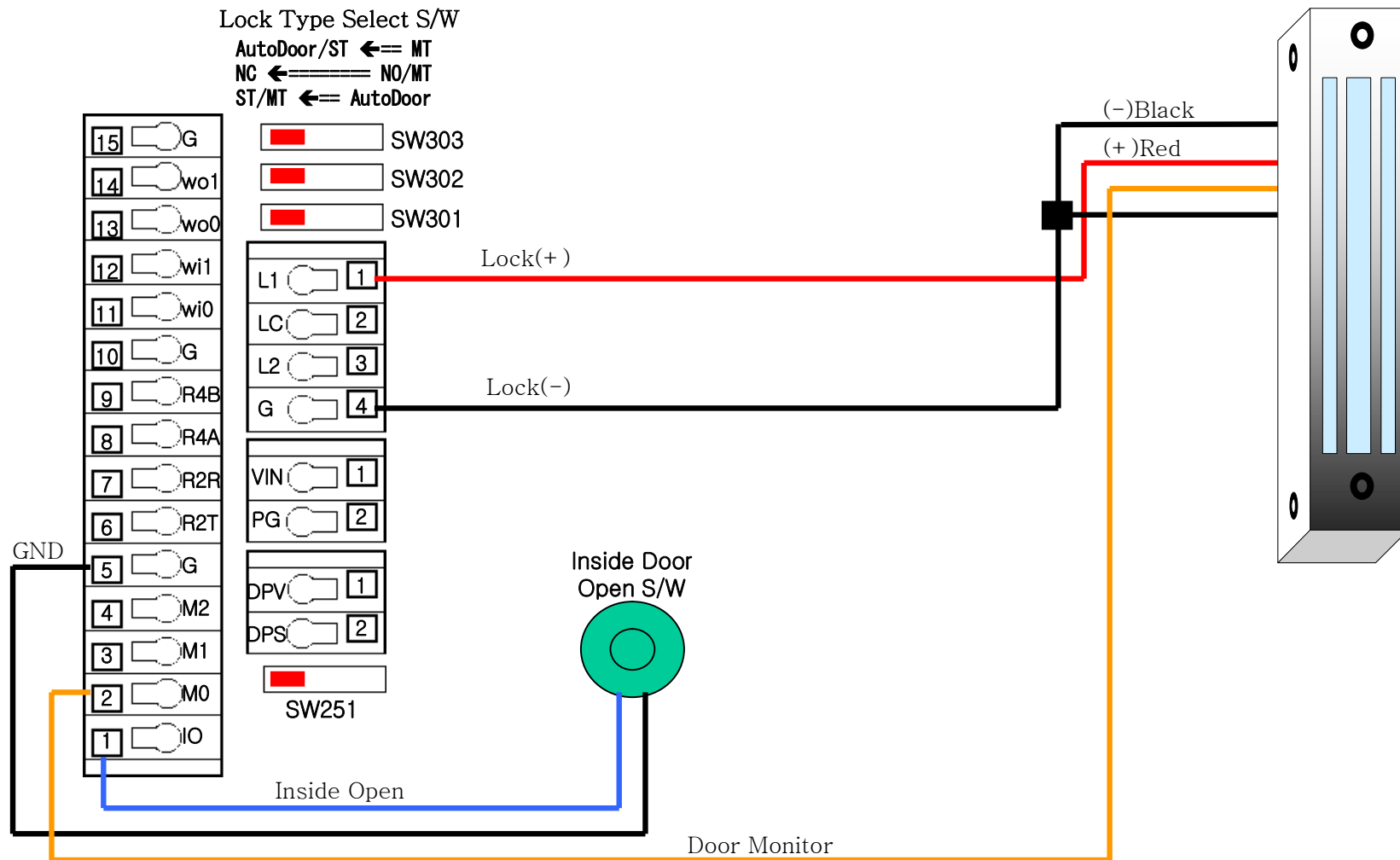

11. Connecting EM Type Door Lock(Fail Safe)

11.2. Connect with Two System/ One Lock

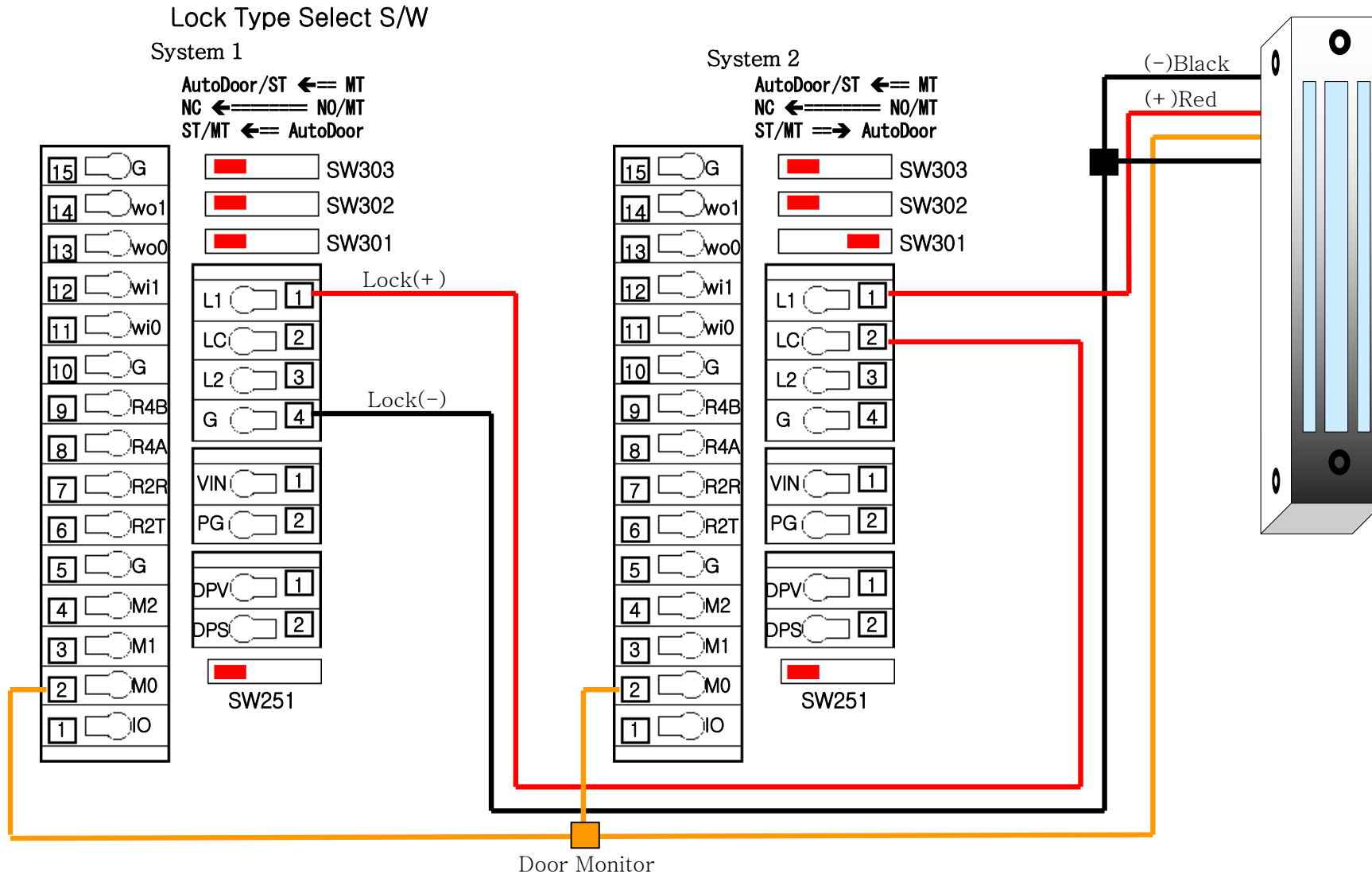

11. Connecting EM Type Door Lock (Fail Safe)

11.3. Connect with One system/ Two Locks ** Use external DC Power adapter

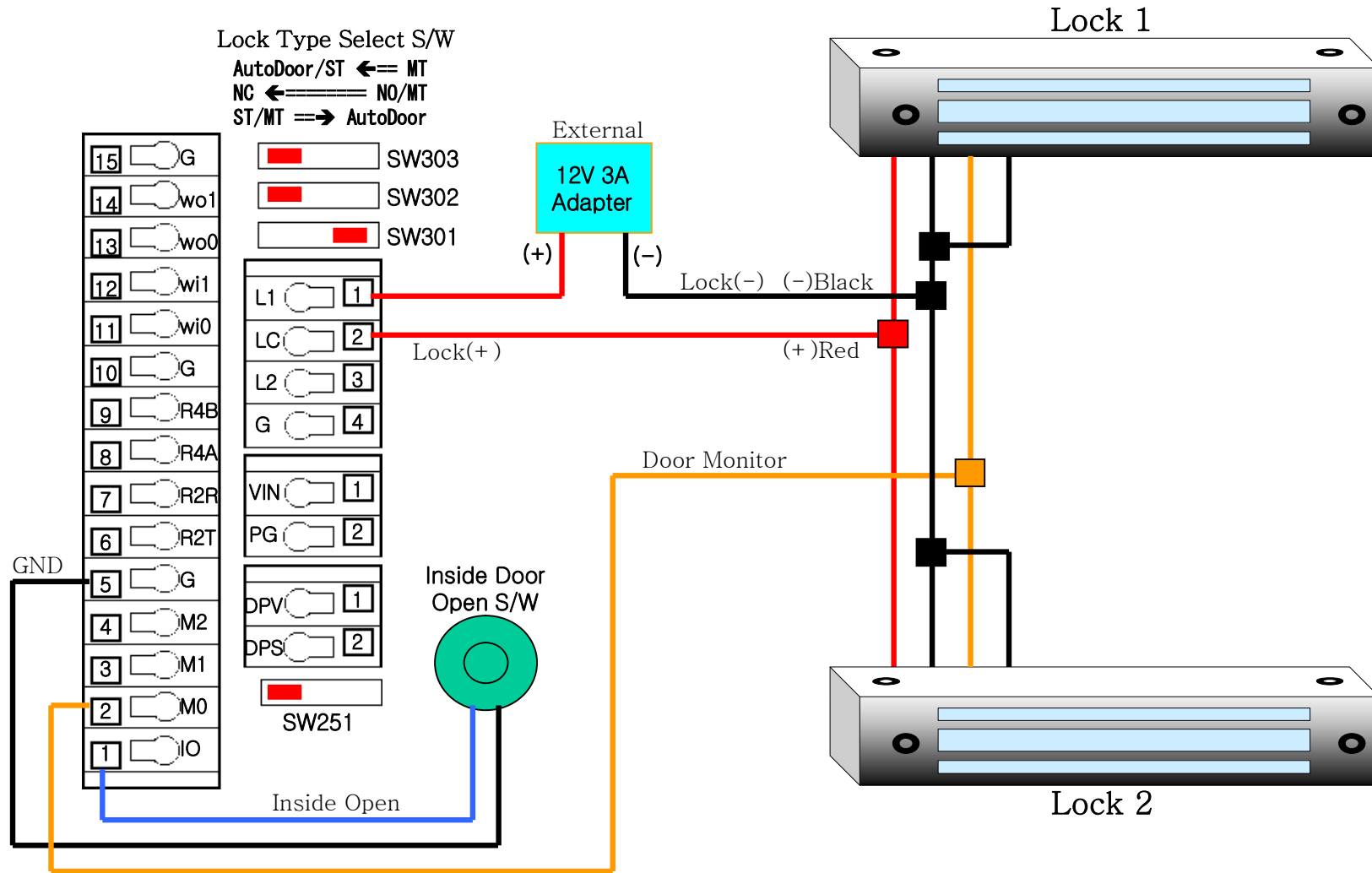

12. Connecting Auto-Door (Contact Control)

12.1. Connect with One system/ One Door

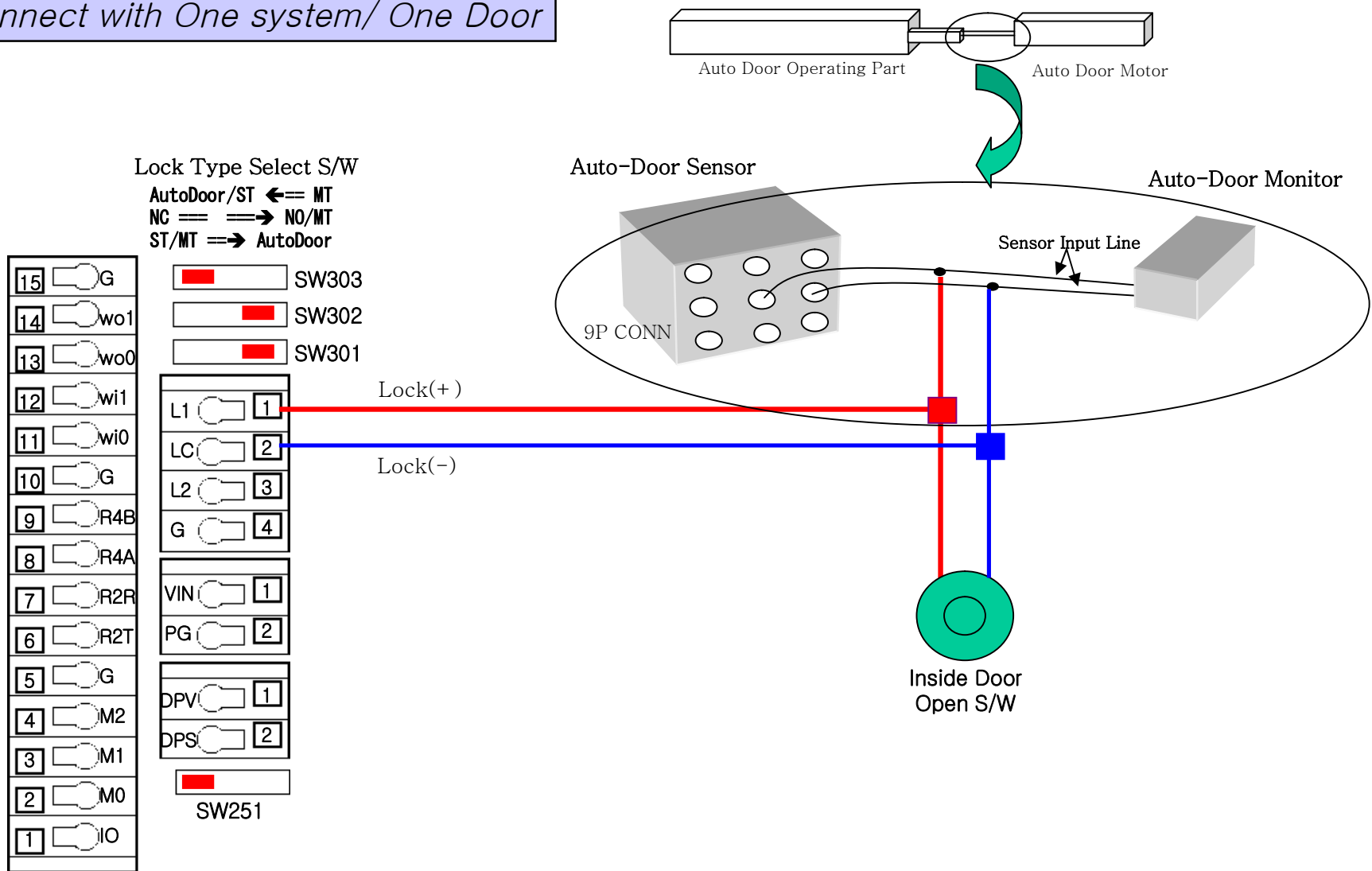

12. Connecting Auto-Door (Contact Control)

12.2. Connect with Two systems/ One Door

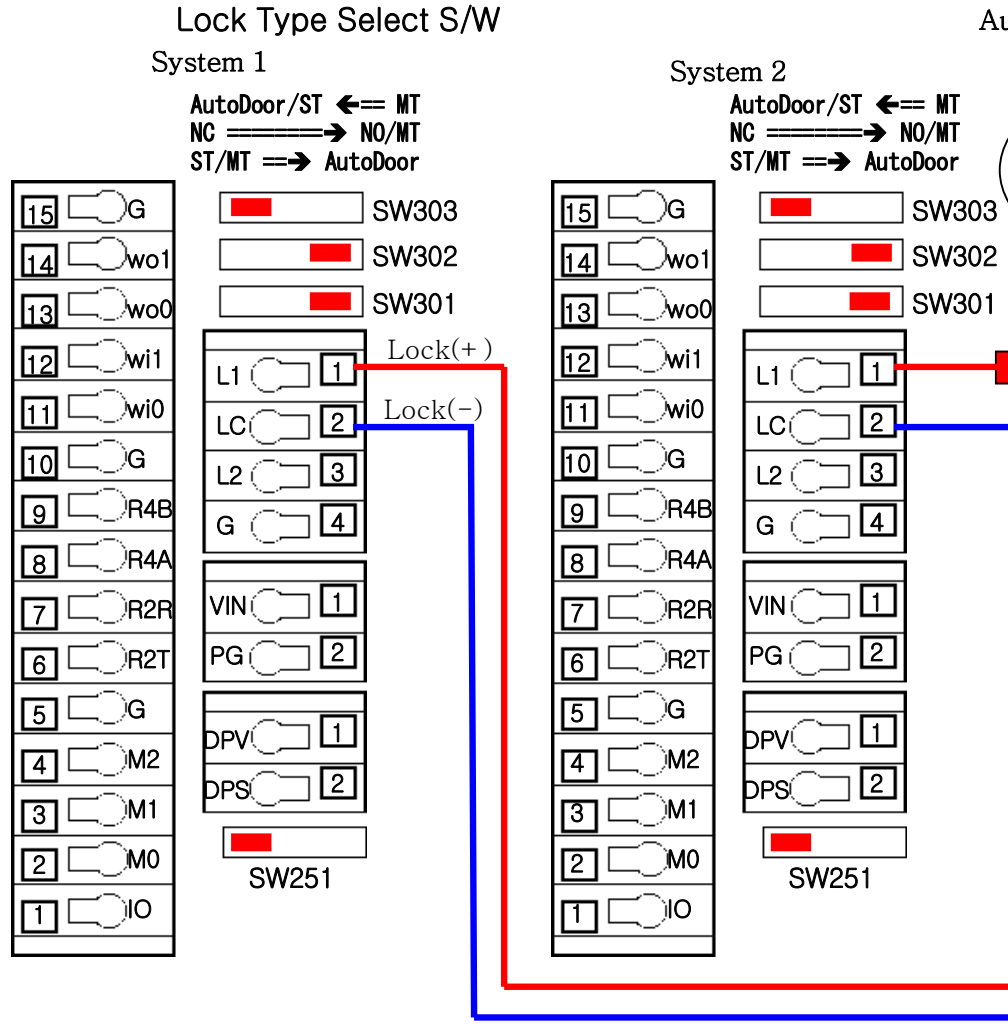
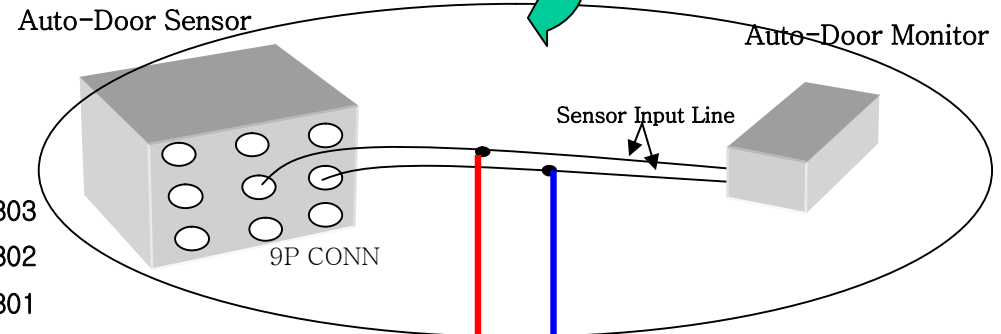
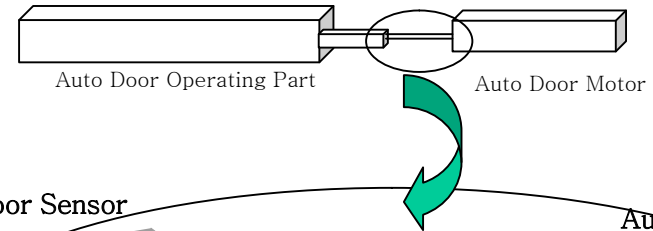

13. Connecting Motor Lock

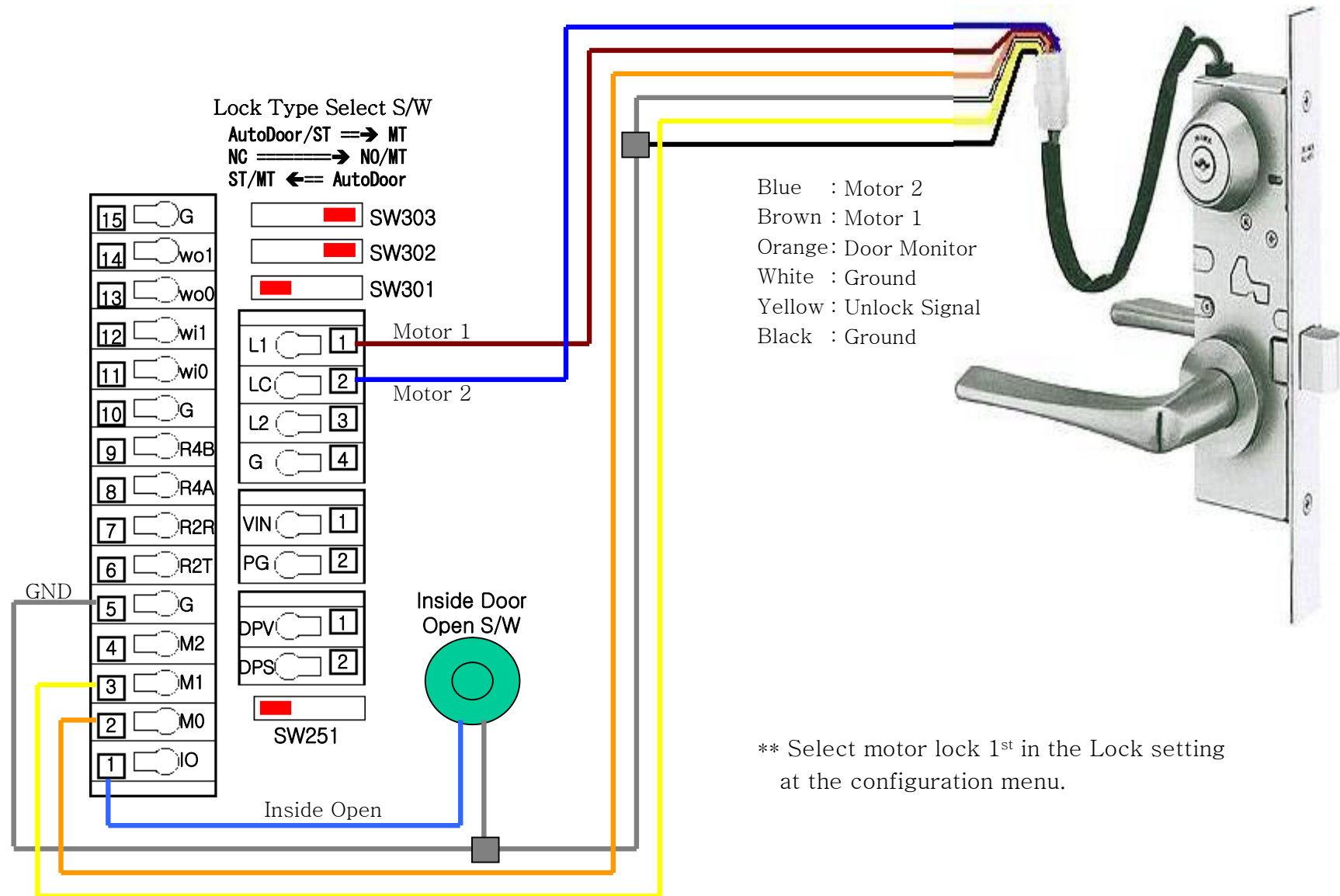

14. Connecting 2 Emergency Lamps

